

WAAS CH <b>66024</b> <b>W14A</b>	APP CRS <b>140°</b>	Rwy Idg TDZE <b>60</b> Apt Elev <b>62</b>	<b>4701</b>
--	------------------------	---	-------------

# RNAV (GPS) RWY 14

SEBRING RGNL (SEF)

**⚠** DME/DME RNP-0.3 NA. Helicopter visibility reduction below 1 SM NA. When local altimeter setting not received, use Vero Beach Muni altimeter setting and increase all MDA 140 feet; increase LP Cat C and D visibility 3/8 mile, LNAV Cat C and D and Circling Cat C visibility 1/2 mile and Cat D Circling 1/4 mile. Night landing: Rwy 14, 32 NA.

**MISSED APPROACH:**  
Climb to 2000 direct  
YOHOR and hold.

AWOS-3 <b>119.475</b>	MIAMI CENTER <b>127.2 317.75</b>	UNICOM <b>122.7 (CTAF) 0</b>
--------------------------	-------------------------------------	---------------------------------

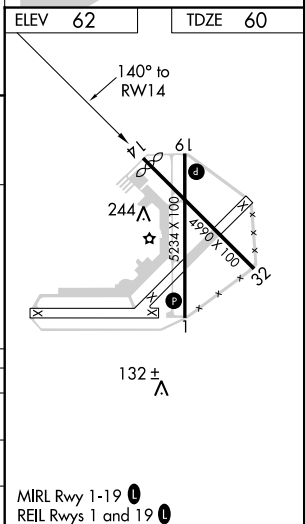
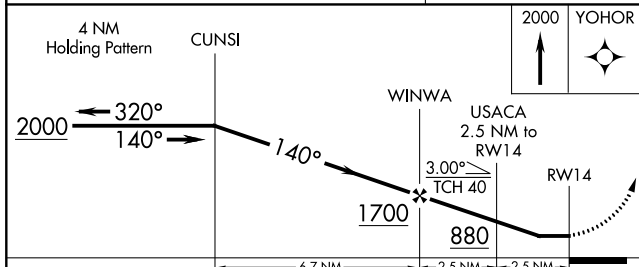
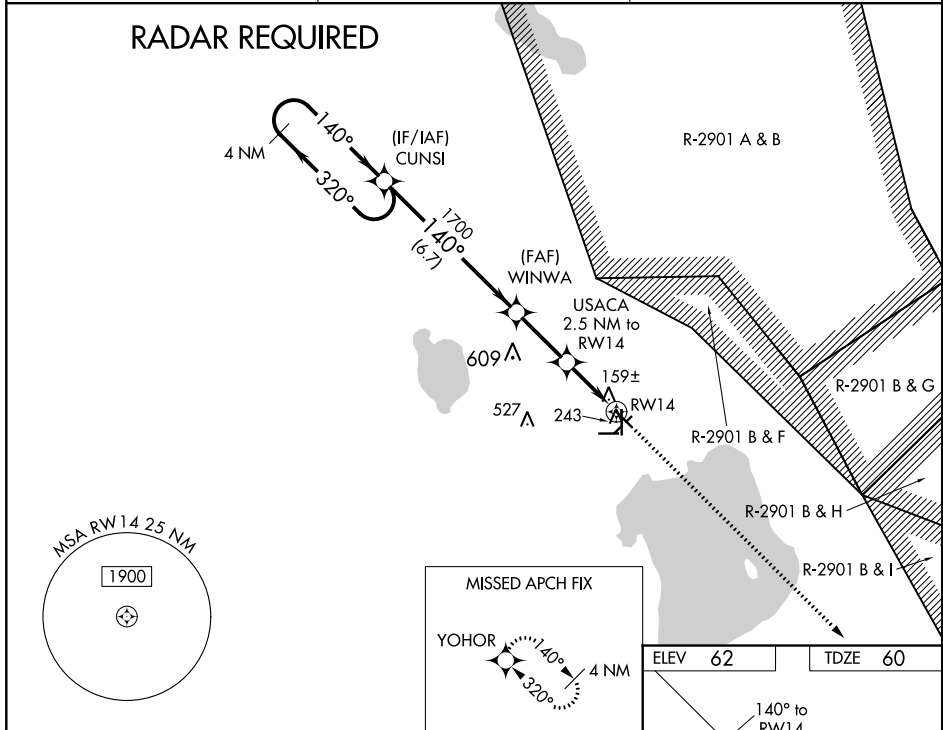

CATEGORY	A	B	C	D
LP MDA	420-1 360 (400-1)			
LNAV MDA	560-1	500 (500-1)	560-1 3/8	500 (500-1 3/8)
CIRCLING	600-1	538 (600-1)	600-1 1/2 538 (600-1 1/2)	620-2 558 (600-2)

MIRL Rwy 1-19 **0**  
REIL Rwy 1 and 19 **0**

SE-3, 12 OCT 2017 to 09 NOV 2017

SE-3, 12 OCT 2017 to 09 NOV 2017