

# BUNTS TWO ARRIVAL

PHILADELPHIA APP CON  
128.4 272.575  
TRENTON MERCER ATIS 126.775  
NEW CASTLE ATIS 123.95  
NORTHEAST PHILADELPHIA ATIS 121.15  
PHILADELPHIA INTL ARR D-ATIS 133.4

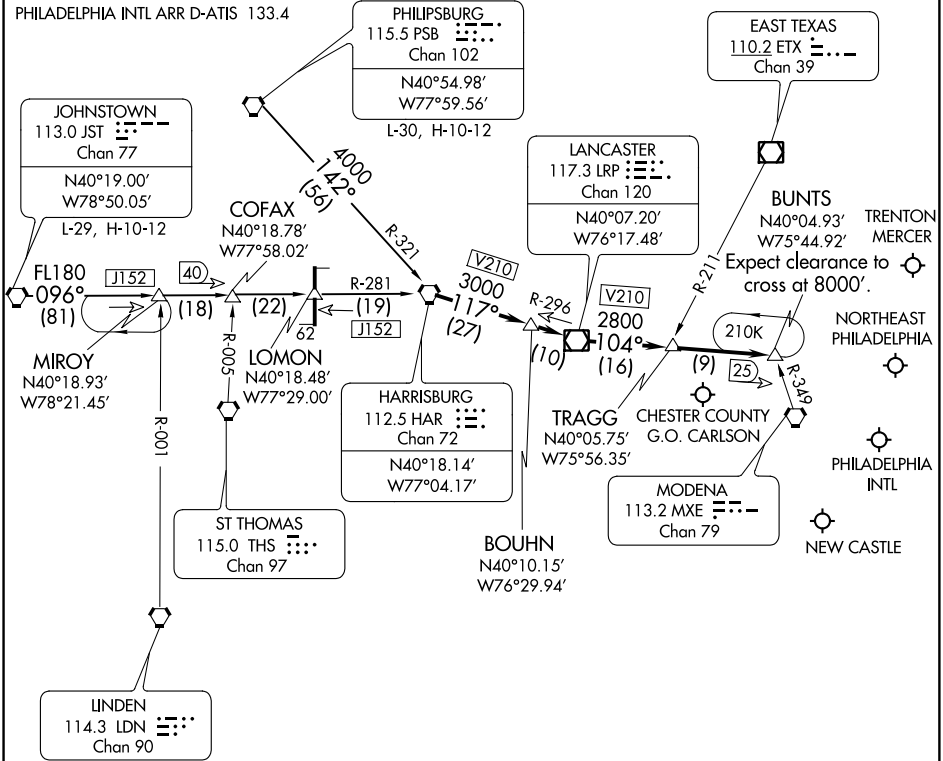

NE-4, 26 APR 2018 to 24 MAY 2018

NE-4, 26 APR 2018 to 24 MAY 2018

NOTE: This STAR is for aircraft capable of 250 KIAS or greater.

NOTE: Chart not to scale.

## JOHNSTOWN TRANSITION (JST.BUNTS2):

## PHILIPSBURG TRANSITION (PSB.BUNTS2):

From over HAR VORTAC via HAR R-117 (V210) and LRP R-296 to LRP VOR/DME, thence via LRP R-104 (V210) to BUNTS INT. Expect RADAR vectors to final approach course.

# BUNTS TWO ARRIVAL